

FQCW266-600

Diode Pumped Continuous Wave Solid State Laser

- 266 nm
- Continuous Wave
- Single Frequency
- Low Power Noise
- Up to 600 mW
- $M^2 < 1.35$, TEM₀₀
- Patented Design (*)



lithography · inspection · spectroscopy · analytics

Optical Data	Wavelength	266 ± 0.2 nm
	Nominal Output Power	600 mW ± 5 %
	Output Power Adjustability	60 mW to 600 mW
	Line Width	< 300 kHz
	Beam Propagation Factor M ² (average)	< 1.3, TEM ₀₀
	Beam Propagation Factor M ² _x (horizontal)	< 1.2, TEM ₀₀
	Beam Propagation Factor M ² _y (vertical)	< 1.35, TEM ₀₀
	Polarisation Orientation and Purity	Vertical, > 500:1
	Beam Diameter	1.1 ± 0.3 mm
	Beam Divergence	< 0.45 mrad
	Static Alignment Tolerance ⁽¹⁾	Lateral ± 0.25 mm Angular ± 2.5 mrad
	Spot-to-Spot Beam Pointing Variation	± 200 µrad
	Power Stability (0.5 Hz over 8 h)	< 0.2 % rms
	Power Noise (1 Hz – 100 kHz)	< 1 % rms
Power Noise (100 kHz – 250 MHz)	< 0.2 % rms	
Lifetime	Typical UV Crystal Spot Lifetime	2,000 hours
	Typical Lifetime (before First Service)	16,000 hours
Electrical Data	Power Consumption Mean (Max)	< 200 W (450 W)
	Line Voltage	90 to 250 V AC (50 to 60 Hz)
	Communication Interfaces	USB RS232 Ethernet
	Safety Features	Key Switch Interlock Electrical Shutter
Miscellaneous	Warm-up Time Typical (Max) ⁽²⁾	< 45 min
	Operating Temperature (Laser Head)	20 °C to 25 °C non-condensing
	Cooling via Bearing Surface, Required Thermal Resistance ⁽³⁾	1/40 K/W @ 25 °C 1/20 K/W @ 20 °C Cooling Surface
	Laser Head Dimensions	< 120 x 311 x 715 mm ³ (H x W x L)
	Control Unit Dimensions	< 184 x 483 x 411 mm ³ (H x W x L)
	Laser Head Weight	< 36 kg
	Control Unit Weight	< 12 kg
Technical Requirement	Purge Supply for Laser Exit Window	Flow 0.2 - 0.5 l/min CDA, SH < 10 PPM or N2 (Purity Grade 5.0 "Scientific" or Better)

Notes:

1. Position and angle of static alignment tolerances are specified with regard to laser beam exit.
2. Warm-up in the temperature range 20 °C to 25 °C, temperature change < 1 K/h.
3. Different cooling options (e.g. air flow, water cooling) available upon request.

(*) Protected by patents:

DE10339210B4, EP1344105B1, US7027209B2, DE102010064382B4, US9429814B2, DE102012212428B4, US9024247.

Dimensions

Laser Head

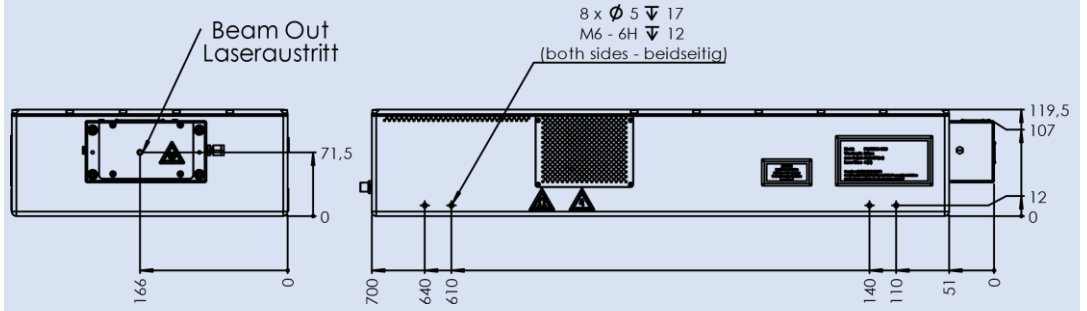

All dimensions in mm.

Control Unit

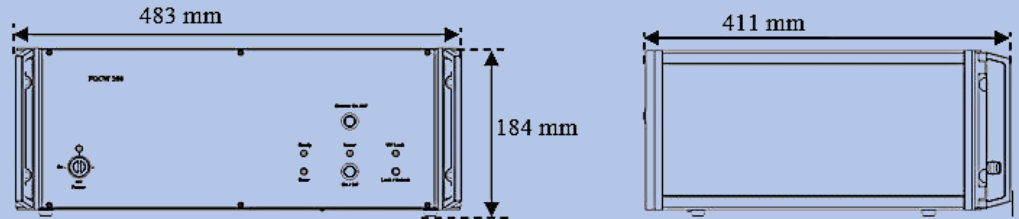

Laser Safety Labels

FQCW266 laser sources are class 4 / IV lasers according to IEC 60825-1

Laser safety labels for the FQCW266 laser source. The labels include:

- Two triangular hazard symbols: one for invisible laser radiation and one for laser radiation.
- A rectangular warning label with the text: **INVISIBLE LASER RADIATION**, **AVOID EYE OR SKIN EXPOSURE TO DIRECT OR SCATTERED RADIATION**, **CLASS 4 LASER PRODUCT**.
- A triangular warning label with the text: **LASER RADIATION IS EMITTED FROM THIS APERTURE**.
- A detailed rectangular label with the following specifications:
 - Model: FQCW266-600
 - Wavelength: 266 nm
 - Max. Output Power: 1200 mW (CW)
 - Laser Class: 4 (IV)
 - Complies with IEC 60825-1:2014
 - Complies with 21CFR 1040.10 and 1040.11 except for deviations pursuant to Laser Notice No. 50, dated July 26, 2001.